

# H038LL1A LGA VERSION

REVISIONS				
REV.	ECO NO.	DESCRIPTION	DATE	DRN
F	09-414	UPDATED PER MKTG REQUESTS	11/19/09	JMR
G	10-162	PIN CAVITY UPDATES/ VARIOUS FIXES	4/26/2010	KDS
H	10-301	PIN TRAVEL/PLATE THICKNESS FIXES	8/6/2010	KDS
J	13-042	TOLERANCE UPDATES	1/18/2013	JLO

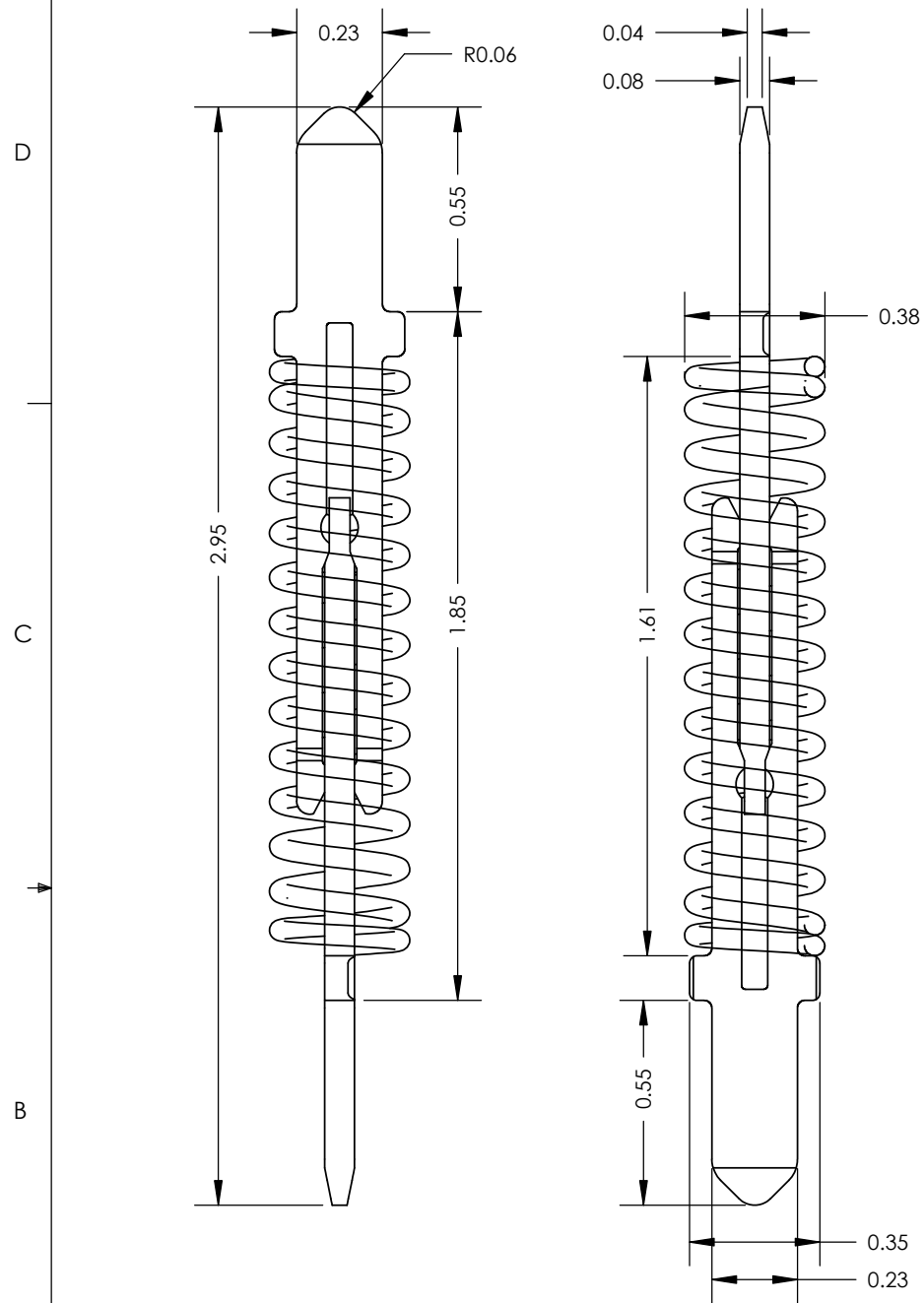

H038 SERIES FORCE DATA (Post-Plating)	
DESCRIPTION	H038XL1A
FORCE @ PIN PRELOAD (0.00mm DEFLECTION)	21.2g
FORCE @ PCB MOUNT (0.10mm DEFLECTION)	23.5g
FORCE @ WORKING TRAVEL (0.43mm DEFLECTION)	30.9g

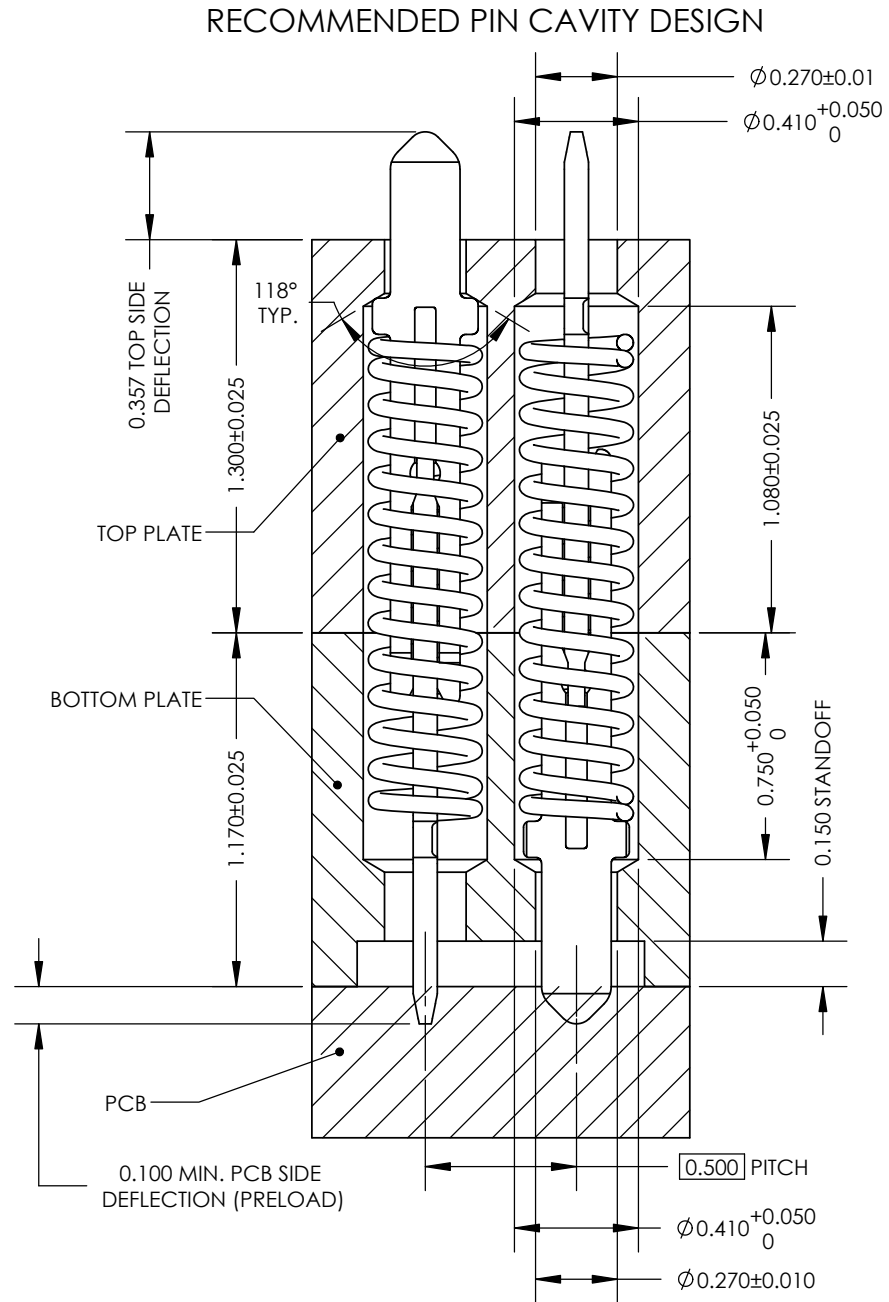
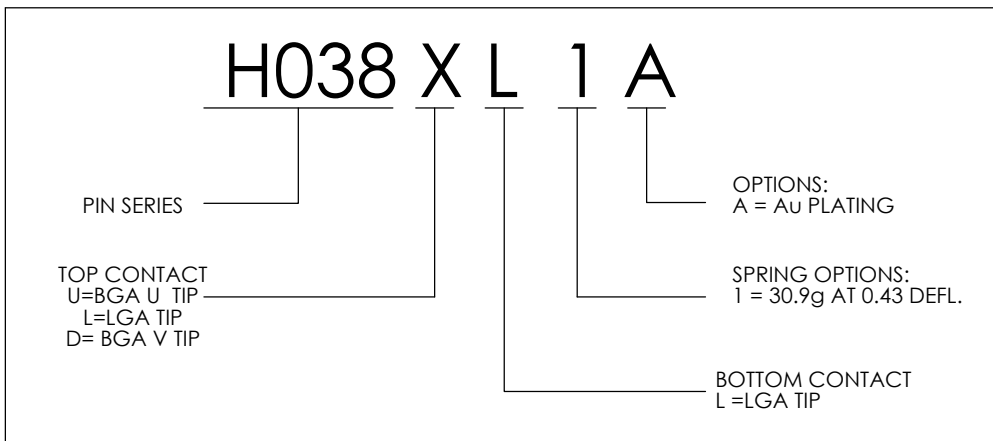

- NOTES:
- RECOMMENDED PCB PRELOAD: 0.1mm MIN.
  - CONTACT MATERIAL: BeCu, Au PLATED OVER Ni
  - SPRING MATERIAL: STAINLESS STEEL, Au PLATED OVER Ni
  - POINTING ACCURACY OF TIP:  $\varnothing$  OF 0.088mm
  - OPERATING TEMP: -55°C TO +180°C
  - CONTACT RESISTANCE: <35 mΩ
  - CURRENT RATING: 2.9A @ ROOM TEMP WITH 30°C TEMP RISE
  - BANDWIDTH @ -1dB: 15.7GHz
  - SELF INDUCTANCE : 0.88nH
  - MECHANICAL LIFE : >125,000 CYCLES
  - PINS ARE SUPPLIED PACKAGED IN AN ANTI-STAT BAG WHICH IS PLACED INSIDE A FOAM-LINED BOX

UNLESS OTHERWISE SPECIFIED	NAME	DATE	2601 Texas Drive Irving, TX 75062
 DIMENSIONS APPLY AFTER PLATING SOLIDWORKS CREATED FILE	DRAWN	4/26/2010	
<b>PROPRIETARY INFORMATION</b> THIS DRAWING AND SUPPORTING CAD DATA IS PROPERTY OF PLASTRONICS SOCKET COMPANY	CHECKED		TITLE: H038 SERIES 0.50mm H-PIN SALES DRAWING
	ENG APPR.		MATERIAL: SEE NOTES
	MFG APPR.		FINISH: NA
SIZE: B	UNITS: mmgs		REV J
SCALE: VAR.	DWG NO. SH038XXXX		SHEET 1 OF 3

# H038UL1A BGA VERSION

## RECOMMENDED PIN CAVITY DESIGN

D  
C  
B  
A

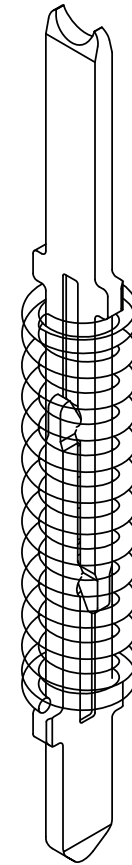
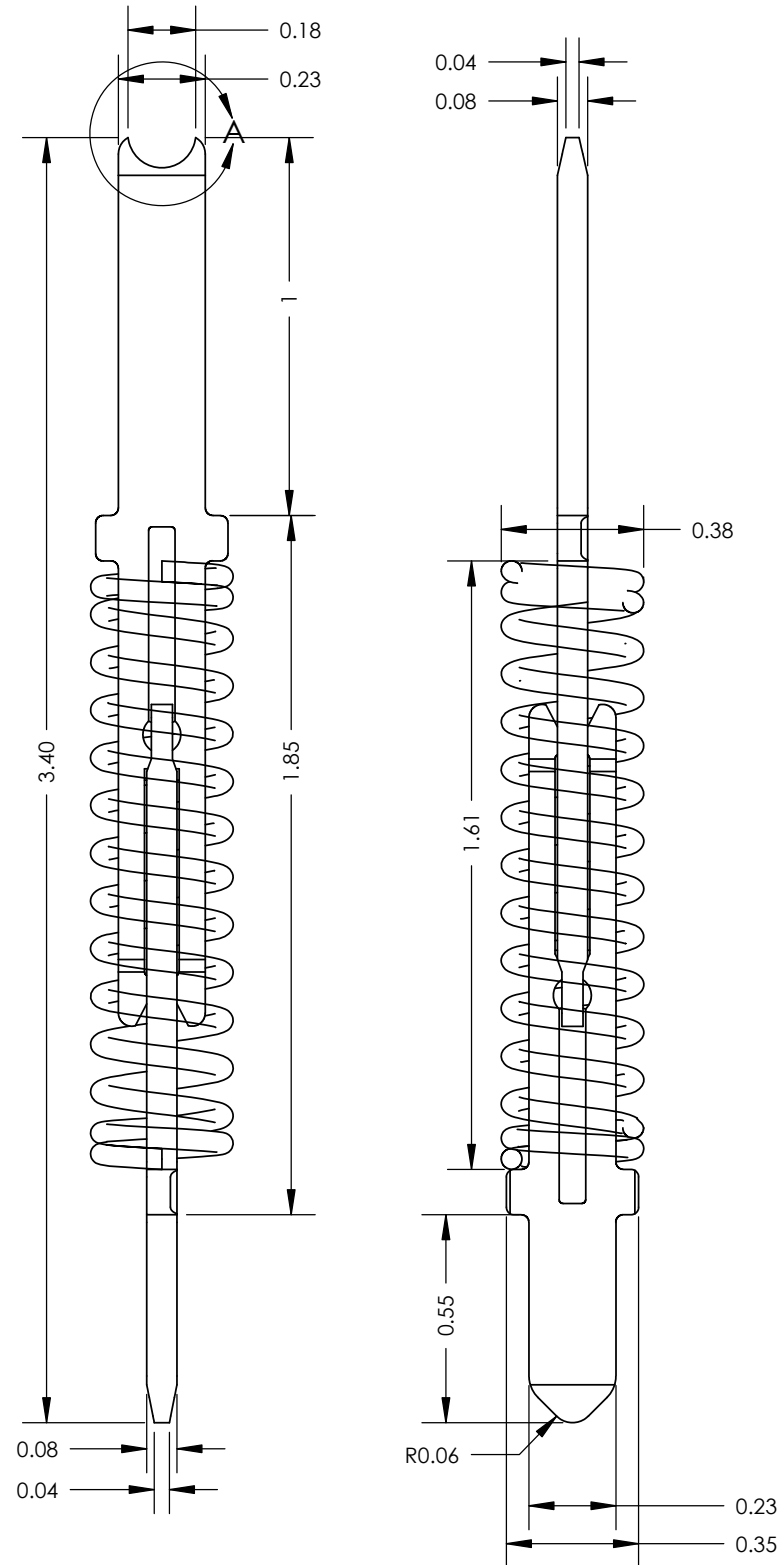

### ACCEPTABLE BALL DIAMETERS

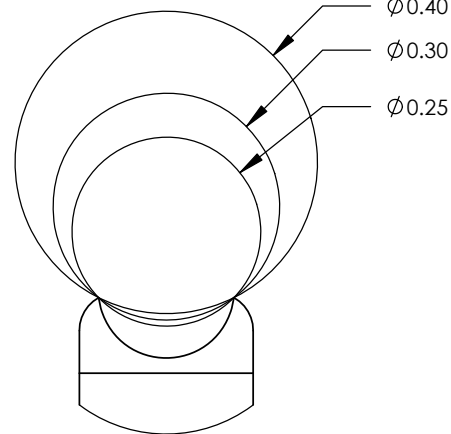

DETAIL A  
SCALE 100 : 1

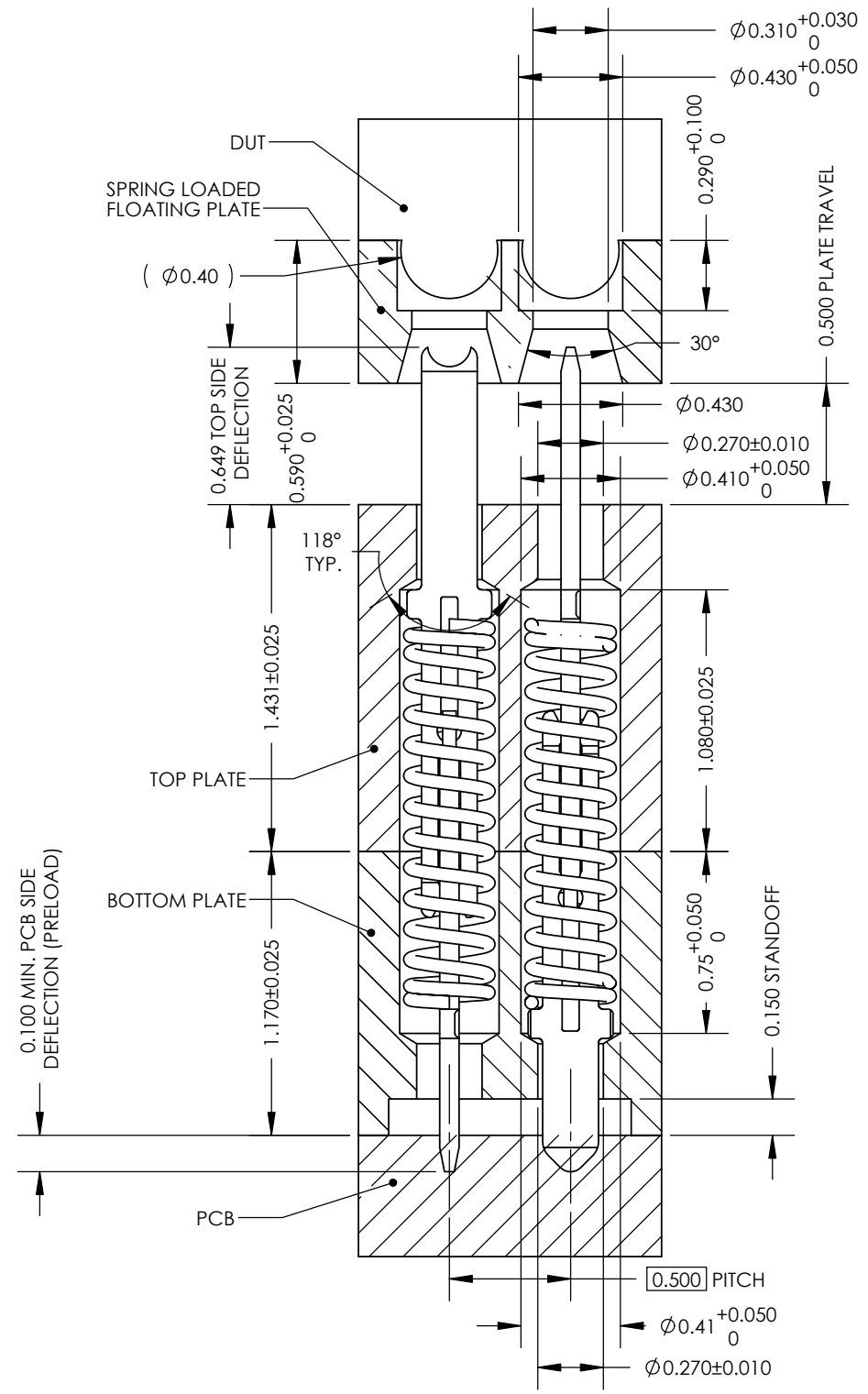

SEE NOTES ON SHEET 1

UNLESS OTHERWISE SPECIFIED	NAME	DATE	2601 Texas Drive Irving, TX 75062	
 DIMENSIONS APPLY AFTER PLATING SOLIDWORKS CREATED FILE	DRAWN	4/26/2010		
<b>PROPRIETARY INFORMATION</b> THIS DRAWING AND SUPPORTING CAD DATA IS PROPERTY OF PLASTRONICS SOCKET COMPANY	CHECKED		TITLE: H038 SERIES 0.50mm H-PIN SALES DRAWING	
	ENG APPR.		MATERIAL: SEE NOTES	
	MFG APPR.		FINISH: NA	REV J
	SIZE: B	UNITS: mmgs		
SCALE: VAR.	DWG NO. SH038XXXX	SHEET 2 OF 3		

8 7 6 5 4 3 2 1

8 7 6 5 4 3 2 1

# H038DL1A BGA VERSION

## RECOMMENDED PIN CAVITY DESIGN

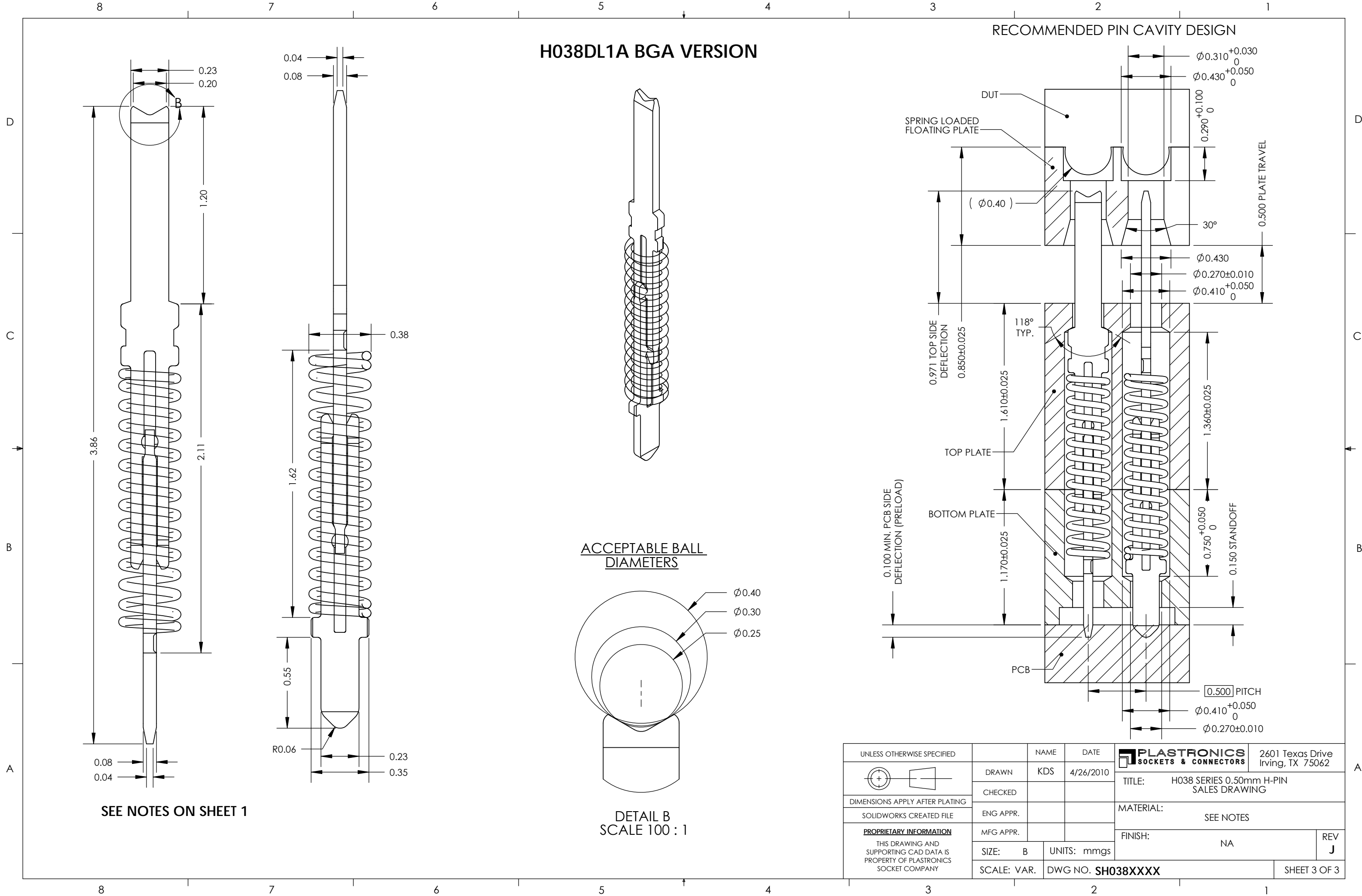

SEE NOTES ON SHEET 1

ACCEPTABLE BALL DIAMETERS

DETAIL B SCALE 100 : 1

UNLESS OTHERWISE SPECIFIED	NAME	DATE	2601 Texas Drive Irving, TX 75062
DIMENSIONS APPLY AFTER PLATING SOLIDWORKS CREATED FILE	DRAWN: KDS	4/26/2010	
<b>PROPRIETARY INFORMATION</b> THIS DRAWING AND SUPPORTING CAD DATA IS PROPERTY OF PLASTRONICS SOCKET COMPANY	CHECKED ENG APPR. MFG APPR.	SIZE: B SCALE: VAR.	TITLE: H038 SERIES 0.50mm H-PIN SALES DRAWING MATERIAL: SEE NOTES FINISH: NA UNITS: mmgs DWG NO. SH038XXXX
			REV J SHEET 3 OF 3